

CABLE RETENTION

Nylon Cable Tie - Standard

These high quality Nylon Cable ties offer smooth rounded edges, a bent tip for easier insertion and a low friction material.

PERFORMANCE	Strength	■
	Temperature	■
	Speed	■ ■ ■ ■ ■
	Weathering	■ ■ ■
	Chemical	■ ■ ■
Dynamic Range	■ ■ ■ ■ ■	

Applications

- Construction
- Electrical
- Fixing Identification
- General Industry

Certifications



E86244 - flammability grade: UL 94 V2



99332 - 97 HH



E-6996



Materials – see section 10.3

- Heat/UV Stabilised ROHS compliant Nylon 6.6.

On Request

- Natural colour

Weathering ■ ■

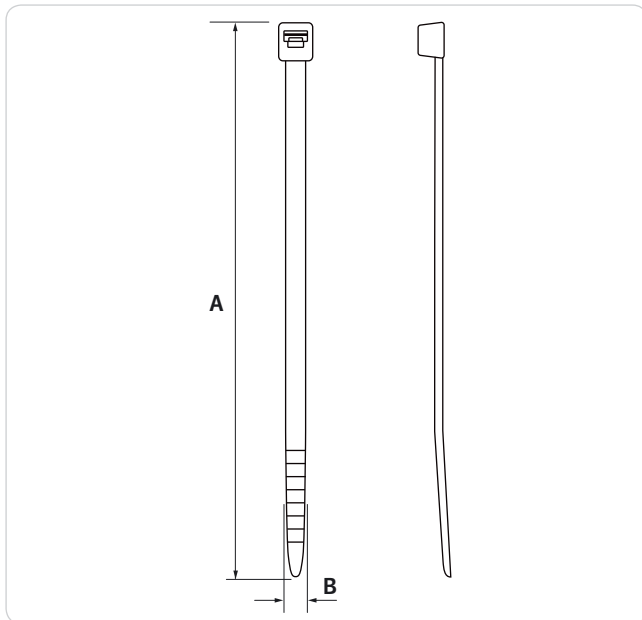

Installation Tools – see section 9.1



MT-PCT-01



MT-PCT-02



MT-PCT-03

HCL Part No	Max Diameter mm	Length (A) mm	Band Width (B) mm	Tensile Strength kg	Box Quantity	
CT-2.2-75	15	75	2.2	6	100	
CT-2.5-98	21	98	2.5	8		
CT-2.5-135	32	135				
CT-2.5-160	40	160				
CT-2.5-200	52	200	3.6	18		
CT-3.6-140	35	140				
CT-3.6-200	50	200				
CT-3.6-290	80	290	4.5	22		
CT-4.5-120	24	120				
CT-4.5-160	40	160	4.8			
CT-4.8-178	45	178				
CT-4.8-200	50	200				
CT-4.8-250	68	250	7.8		55	
CT-4.8-290	78	290				
CT-4.8-360	100	360				
CT-4.8-430	115	430	7.5			
CT-7.8-120	25	120				
CT-7.8-180	45	180	7.8	71		
CT-7.8-240	63	240				
CT-7.8-300	80	300				
CT-7.5-365	100	365	9.0			110
CT-7.5-450	130	450				
CT-7.5-540	158	540				
CT-7.8-750	220	750	12.5		110	
CT-9.0-780	233	780				
CT-12.5-225	57	225				
CT-12.5-500	143	500	12.5			
CT-12.5-720	213	720				
CT-12.5-850	255	850				
CT-12.5-1000	302	1000				

All weights, dimensions & quantities are subject to a 2.5% tolerance. To add material selection to the HCL Part No: for Nylon 6.6. Black, add "-PA66-BK".