

# WORM DRIVE & SCREW CLAMPS



## Worm Drive BS5315

HCL's British Standard Worm Drive clamps are manufactured in accordance with BS5315, using a "Spot Weld" type housing.

PERFORMANCE	Strength	Temperature	Speed	Weathering	Chemical	Dynamic Range
	4	4	4	4	4	4

### Applications

- Agricultural
- HVAC
- Automotive
- Plumbing & Sanitary
- Fluid Transfer
- White Goods
- Hardware
- General Industry

### Materials – see section 10.3

- **W1** Zinc Plated Steel

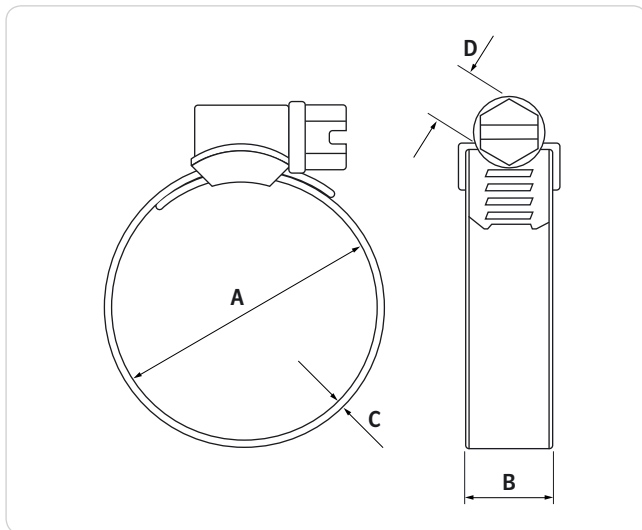

HCL Part No	Diameter Range (A) mm	Band Width (B) mm	Band Thickness (C) mm	Hex Screw A/F (D) mm	Max Torque Nm	Box Quantity	
WD-BS-000-SW	10 – 16	9.7	0.8	7.0	3.5	1200	
WD-BS-00-SW	13 – 19					1000	
WD-BS-0-SW	16 – 25					1200	
WD-BS-0X-SW	19 – 29	11.7			5.0	600	300
WD-BS-1A-SW	22 – 32						
WD-BS-1-SW	25 – 38						
WD-BS-1X-SW	32 – 44						
WD-BS-2A-SW	35 – 51						
WD-BS-2-SW	38 – 57						
WD-BS-2X-SW	44 – 64						
WD-BS-3-SW	51 – 70	5.0			250	100	
WD-BS-3X-SW	64 – 76						
WD-BS-4-SW	70 – 89						
WD-BS-4X-SW	76 – 92						
WD-BS-5-SW	80 – 100						
WD-BS-5X-SW	90 – 110	5.0	100				
WD-BS-6-SW	100 – 120						
WD-BS-6X-SW	110 – 130						
WD-BS-7-SW	120 – 140						

All weights, dimensions & quantities are subject to a 2.5% tolerance.  
To add material selection to the HCL Part No: for W1, add "W1".

### Installation Tools – see section 9.1



MT-D-01

MT-AD-01

MT-TD-01